



Cattron™ PumpBossIII

User Manual

9M02-9345-A002-EN



CONNECT. CONTROL. PROTECT.

Revision History

VERSION	DATE	NOTES
1.0	08-01-23	Initial Release per ECO-23-0315
2.0	06-14-24	Updated with addition of 915MHz, information on LED indication and CANbus Interface

Any information furnished by Cattron™ and its agents is believed to be accurate and reliable. All specifications are subject to change without notice. Responsibility for the use and application of Cattron products rests with the end user since Cattron and its agents cannot be aware of all potential uses. Cattron makes no warranties as to non-infringement nor as to the fitness, merchantability, or sustainability of any Cattron products for any specific or general uses. Cattron Holdings, Inc., or any of its affiliates or agents shall not be liable for incidental or consequential damages of any kind. All Cattron products are sold pursuant to the Terms and Conditions of Sale, a copy of which will be furnished upon request. When used as a tradename herein, Cattron means Cattron Holdings, Inc. or one or more subsidiaries of Cattron Holdings, Inc. Cattron™, corresponding logos, and other marks are trademarks or registered trademarks of Cattron Holdings, Inc. Other marks may be the property of third parties. Nothing herein provides a license under any Cattron or any third-party intellectual property right.



Contents

1.	Introduction.....	5
1.1	Terminology	5
2.	Warnings and Cautions	6
2.1	Warnings	6
2.2	General Safety Information	6
2.3	Improper Use	7
2.4	Safety Instructions for Assembly / Disassembly	7
2.5	System Addressing	7
3.	What is PumpBossIII.....	8
4.	Typical System Overview	8
5.	PumpBossIII MCU Overview	8
5.1	PumpBossIII MCU Key Features	9
6.	PumpBossIII MCU Mechanical and Installation	10
6.1	Main Assembly.....	10
6.2	Mounting Details	11
6.3	Module Installation	12
6.4	Antenna(s) Installation	12
7.	Module Features.....	14
7.1	Main Assembly.....	14
7.2	Radio Module	15
7.3	SD Card	15
7.4	Digital (SSR) Outputs.....	15
7.5	CAN interface.....	16
7.6	CAN Termination.....	18
7.7	Cable Harness	19
7.8	Status LEDs	21
7.9	Data Logging.....	24
8.	System Configuration.....	24
8.1	Operating Frequency	24
8.2	System Address	24
9.	The Controlled Machine	27
9.1	Control Power	27
9.2	Main Safety Outputs.....	27
9.3	Circuit Breakers.....	27
9.4	Interfacing to the machine.....	27



10	Operation	28
10.1	Post Installation.....	28
10.1	Associating an OCU with a CBMCU	28
10.2	Turning on your OCU.....	29
10.3	Transition to Active Mode.....	30
10.4	Transition to Passive Mode.....	31
10.5	Transition to OFF Mode	31
10.6	SUMMARY OF TURN ON PROCEDURE	31
10.7	Daily Operation	31
10.8	Service	31
10.2	De-commissioning.....	32
11	Configurations	32
11.1	PBIIS-1	32
11.2	PBIIS-2.....	33
11	CattronLink™	34
12	Requirements to Achieve PLd within a 'System'.....	35
13	PFHd Values	35
14	Technical Specifications	36
15	CE Declaration of Conformity	36



1. Introduction

This manual relates to Cattron's PumpBossIII MCU System.

Any variations in system-specific data is provided in the technical documentation accompanying the delivery of the system or in the relevant 'Standard Configuration Sheet'.

1.1 Terminology

The following represents important acronyms and long form names used in this document:

- OCU – Operator Control Unit, historically referred to as a *transmitter*
- MCU – Machine Control Unit, historically referred to as a *receiver*
- ASO – Automatic Safety Override; in this unit, fully automatic system shutdown made possible by the use category 3 architecture coupled with cascading digital outputs with multi-stage monitoring and a CAN data system handled and verified by both microcontrollers to ensure 100% accuracy on data handling.
- OTA – Over The Air primarily related to RF communication
- Firmware – The Operating system or embedded programming responsible for the devices core safety and feature set.
- Configuration – The parameters used by the firmware to the set the functionality such as RF Frequency, Addressing, CAN and digital mapping etc.
- UI – User interface
- Software – The program running on the PC used to interface with the device and providing the UI for programming, configuration and data-log download.



2 Warnings and Cautions

2.1 Warnings

WARNING statements have been strategically placed throughout all text prior to operating or maintenance procedures, practices, or conditions considered essential to the protection of personnel or equipment and property. A WARNING applies each time the related step is repeated. Before starting any task, the WARNINGS included in the text for the task should be reviewed and understood.

WARNINGS appearing in this manual follow the general format below.

	WARNING
	Description of warning Possible consequence of non-compliance

2.2 General Safety Information

- Persons under the influence of drugs, alcohol and/or other medicine that impairs reaction may not assemble, disassemble, install, put into operation, repair or operate the product.
- All conversions and modifications of an installation or system must conform to the relevant safety requirements.
- Only qualified, trained, authorized personnel may perform work on the equipment, in accordance with the relevant safety requirements.
- In the event of malfunction and/or visible defects or irregularities, the product must be stopped, switched off, and isolated.

	WARNING
	Observe the statutory regulations and directives applicable for the intended purpose, e.g.: Accident prevention regulations Safety rules and directives Standards Generally applicable statutory and other binding regulations for accident prevention and environmental protection, and general safety and health requirements.

- Ensure that users have access to the user manual.
- The personnel assigned to work on/with the product must have read and understood this operating manual and the safety instructions.
- The safety instructions must, if necessary, be supplemented by the user with instructions concerning the work organization, work sequences, qualified personnel, etc.
- All repairs made during the warranty period must be carried out by the manufacturer or appointed authorized service center; failure to comply will invalidate the warranty.
- All repairs made should be carried out in a suitably clean static-safe environment, free from contaminants such as metal filings, water, oil, etc.



- It is the user’s responsibility to ensure that the product always operates in good condition and that all applicable safety requirements and regulations are observed.
- Product modifications may not be carried out without the consent of the manufacturer.
- Original spare parts from the manufacturer must be used.
- Carry out periodic inspections and/or maintenance either required by law or prescribed in the user manual within the required intervals.

2.3 Improper Use

Ensure compliance with equipment ratings and operate only as intended, in particular:

- Ensure the machine is in a safe state before installation/maintenance
- Check that power supply voltage / polarity is correct
- Do not misuse or exceed operating specifications
- Ensure periodic maintenance routines are observed

	CAUTION
	<p>Damage to the device: Do not exceed the units ratings including its environmental ratings, for environments harsher than rated, use an appropriate secondary enclosure. Neglecting the above can result in danger for life and limb and/or cause physical damage to the product or the environment.</p>

2.4 Safety Instructions for Assembly / Disassembly

- Isolate the system from the electrical power.
- Observe user-specific regulations.
- Only use suitable tools.
- Secure the installation area.

2.5 System Addressing

To ensure safe operation, systems are configured with a unique address, this may be automatic or manually assigned.

	CAUTION
	<p>Conflict of Addresses: Addresses are never repeated and must be System Unique. The user must ensure that the system address and addressing mode is used as designed. If the address has been manually assigned it must be ensured that there is never a duplication of address on any other systems in the operating area over the entire life of the system. In the event of a breach of this undertaking, the user is liable for any resulting damage/loss and shall indemnify the manufacturer against all third-party liability claims.</p>



3 What is PumpBossIII

The PumpBossIII System typically comprises of a PumpBossIII MCU and a corresponding PumpBossIII OCU, although other configurations are possible.

The PumpBossIII MCU is in effect a low-complexity system level Safety PLC that incorporates a single CANbus (J1939 or CANopen) and 8 solid-state digital outputs.

The Architecture and operation of these interfaces meet a functional safety level PLd according to EN ISO 13849.

PumpBossIII MCU achieves its Functional Safety level by employing a full category 3 architecture, dual cross channel handling and monitoring of all CAN data and digital output states.

4 Typical System Overview

While many variations are possible a typical system comprises a PumpBossIII MCU plus one or two OCUs plus accessories.

The matching OCU is typically based on a 411, but other OCUs such as the 611 may be used.

The OCU and the PumpBossIII MCU are linked by a secure RF communication system and the PumpBossIII MCU drives the machine via the chosen interface (CAN, digital or both). Therefore, the machine is under the direct control of the OCU and hence operator.

The PumpBossIII MCU is available with standard configurations or custom designed configurations tailored to control most applications, this provides a great deal of flexibility to make the solution exactly fit your needs.

Standard Systems configurations, and other media are available on the www.Cattron.com website under the specific product resources tab.

These systems feature an ability to wirelessly connect to the OCU or PumpBossIII MCU over Bluetooth® and upgrade firmware to take advantage of new features as they are released as well as the ability to wirelessly change configuration items such as system, address, digital or CAN functionality, or examine data-logs etc.

PumpBossIII operating in the 2.4 GHz frequency band requires no frequency or address management as the OCU and MCU pairing is achieved through a simple association process.

5 PumpBossIII MCU Overview

These MCUs have been designed with the latest generation safety electronics and firmware and exceed the safety related systems requirements for ISO13849 Category 3 PLd for the stop function and control functions.

The PumpBossIII MCU is equipped with two antenna ports, that provide an antenna diversity capability to provide the best possible RF communication, the typical operating range is 180-240m (600-800ft).

As standard a single antenna is supplied but a second antenna can be added for challenging RF environments.

The MCU incorporates a wide range 9-36VDC supply designed to operate in a harsh mobile environment.

Status and feedback are provided by multiple Tri and Bi colored LEDs for power and general status.

The PumpBossIII MCU is housed in a compact fully screened aluminum enclosure to meet the challenging environmental and electromagnetic standards required for mobile applications.

Approved to comply with the appropriate Safety standards applicable to the region or country of use.



5.1 PumpBossIII MCU Key Features

Next generation design meeting performance Level d (PL-d) according to EN ISO13849 for all digital outputs, additionally CAN support is realized in a full category 3 architecture ensuring total fidelity of the CAN messaging independently of the CAN protocol.

2.4GHz and 915MHz Long Range communication with optional RF diversity and a robust and easy to install antenna system.

A Wide-range power supply covering 9-36VDC, engineered for mobile applications.

Bluetooth® closed box link for wireless uploads and downloads.
Providing access to.

- Firmware upgrades.
- Unit Configuration such as frequency, address, CAN setup etc.
- Functional Configuration changes such as digital mapping, CAN mapping etc.
- Downloads of Diagnostics and Logged Data.

Diagnostics and logging is built in and record warnings, faults, changes, totalizers, durations etc., with real time clock onto an internal SD card able to store an extensive amount of data.

Two tri-color and six bi-color LEDS provide quick and intuitive status information.

Eight 9-36VDC Solid State PLd outputs, two at 10A and six at 4A, all support hit and hold PWM functionality and up to two may be defined as main power control outputs.

Single category 3 PLd CAN port supporting either J1939 2.0B 250-500kbs or CANopen at data rates of 10kbs to 1MBs.

A 23 pin AMP connector PROVIDES all interface connections, each unit is provided with a pre-wired matching Plug and 2m cable.

The compact fully screened aluminum enclosure is rated at IP66 and is pre-drilled for four easy to access mounting attachment points. The full aluminum housing ensures that the electronics are fully protected from high levels of electromagnetic interference.



6 PumpBossIII MCU Mechanical and Installation

6.1 Main Assembly

Figure 1 Exploded view

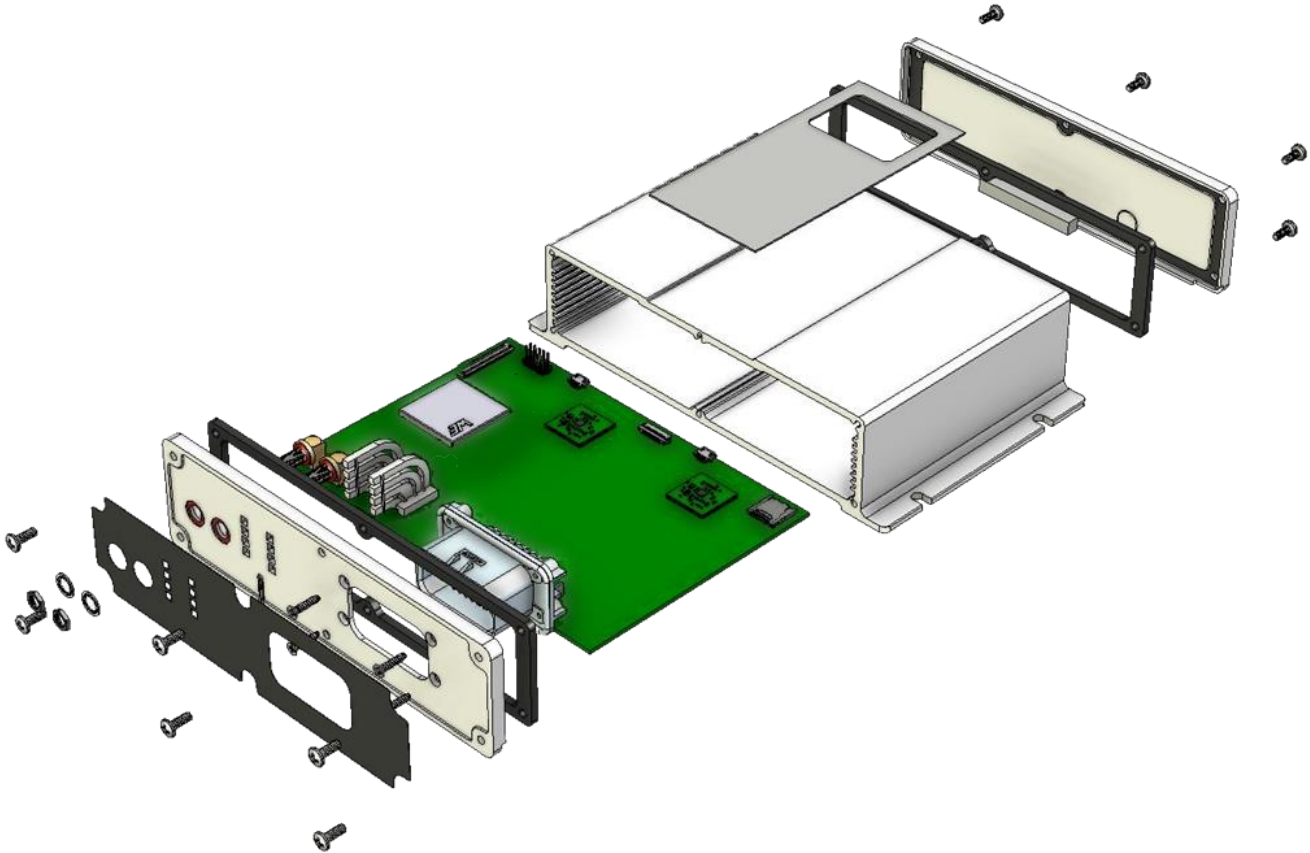

The MCU is a sealed assembly and because configuration is mostly via Bluetooth® opening the enclosure is not normally required.

The main body is an aluminum extrusion, and it has two sealed end caps, the rear end cap is secured by 8 screws and would not normally need to be accessed.

The front-end cap is directly attached to the printed circuit assembly, if it is necessary to access the electronics then remove the front 6 screws and slide the electronic assembly out, this should only be done in a clean dry environment.

The MCU has two side flanges with slots for securing the MCU to a fixing location with screws.



6.2 Mounting Details

Figure 2 Mounting dimensions main enclosure

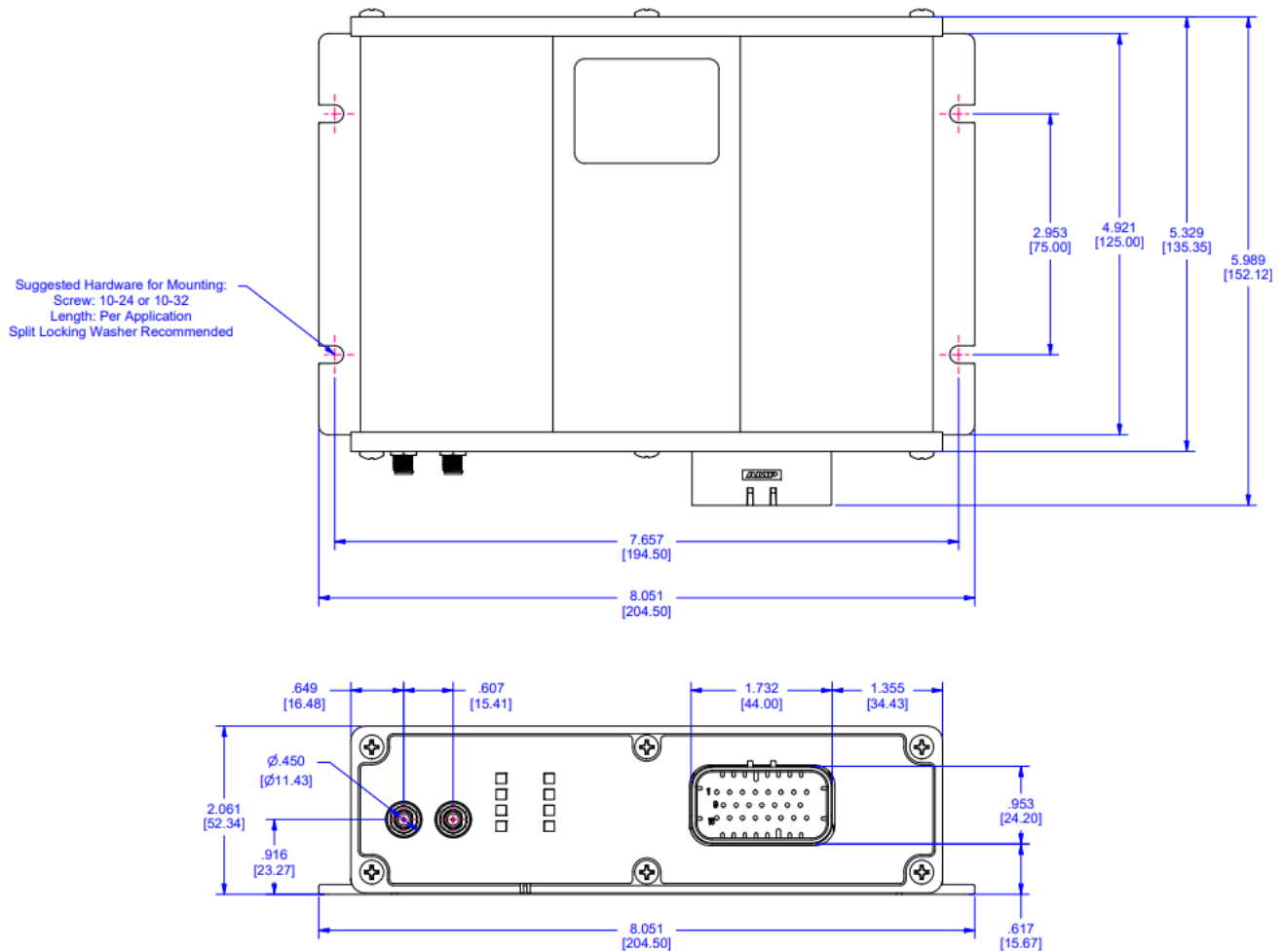
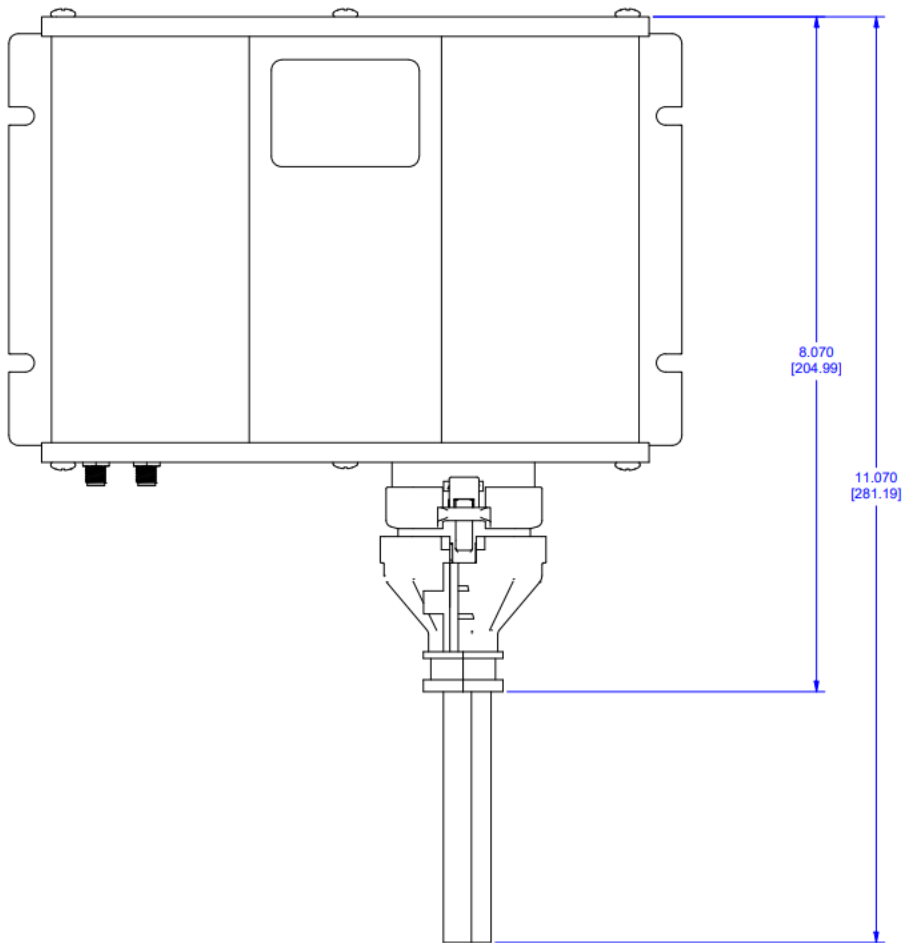

Figure 3 Mounting dimensions multi-IO connector



6.3 Module Installation

The MCU should ideally be mounted in a location that is protected from heat and constant vibration, in all cases ensure the unit does not exceed its environmental specifications. Allow clearance for the antenna and multi-pin connector cables, ensure the antenna cables are not kinked.

Positioning that allows the LEDs to be viewed can be advantageous when checking status.

There are 4 slots in the mounting flanges, each slot is 5mm (3/16 inch) wide so able to take M4, M4.5 or size 10 screws, A spring and flat washer should be used above the flange.

6.4 Antenna(s) Installation

The PumpBossIII MCU system is supplied as standard with one antenna and line kit.

To ensure optimum communication, the OCU and MCU antenna should ideally maintain line of sight for best operating distance and any solid obstacles such as solid walls or dirt mounds avoided.

The antenna is normally mounted directly on the machine or on the angle bracket provided as shown below.



The Coaxial cable should be securely connected to the antenna and the connector on the MCU, the second antenna port if unused should be capped with the blanking cap provided.

Figure 4 Antenna Mounting

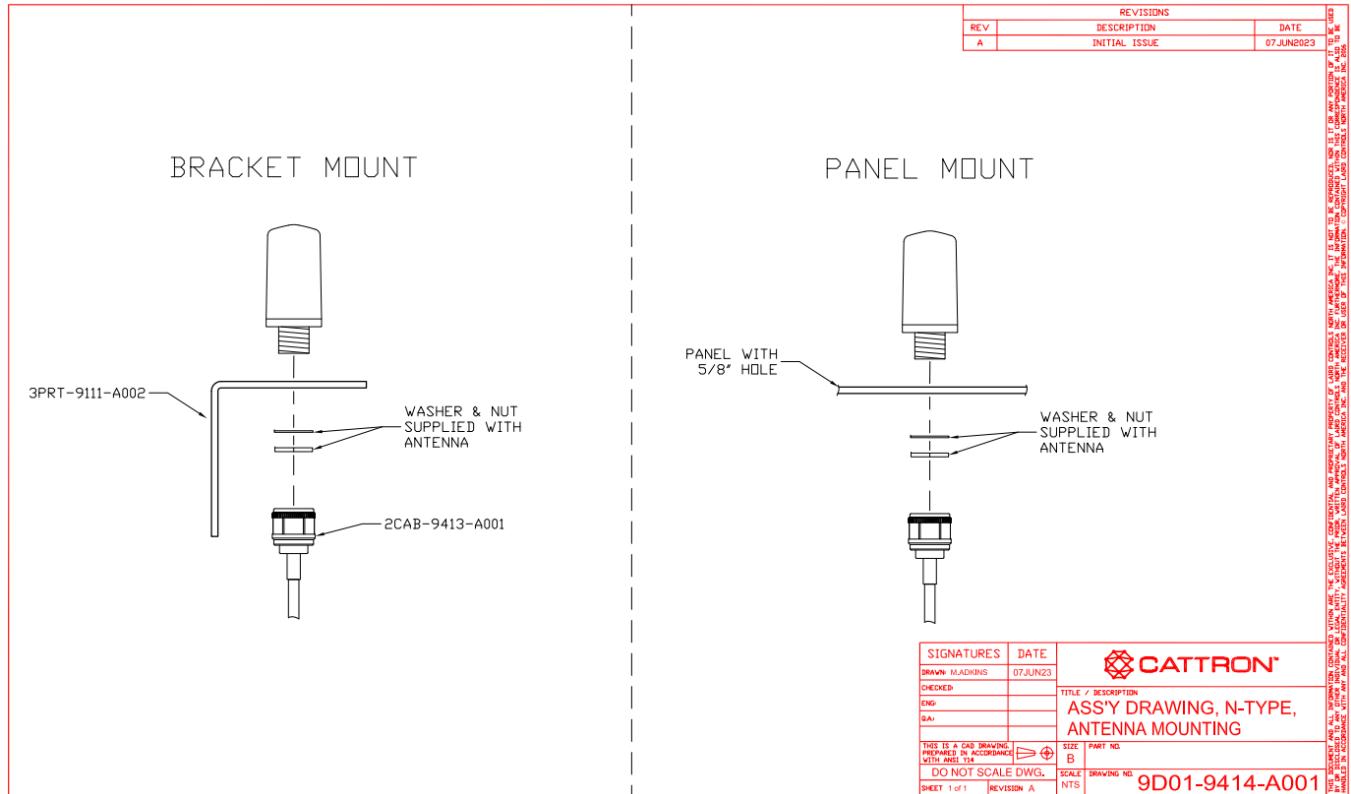

7 Module Features

7.1 Main Assembly

Figure 5 PCA Primary Components

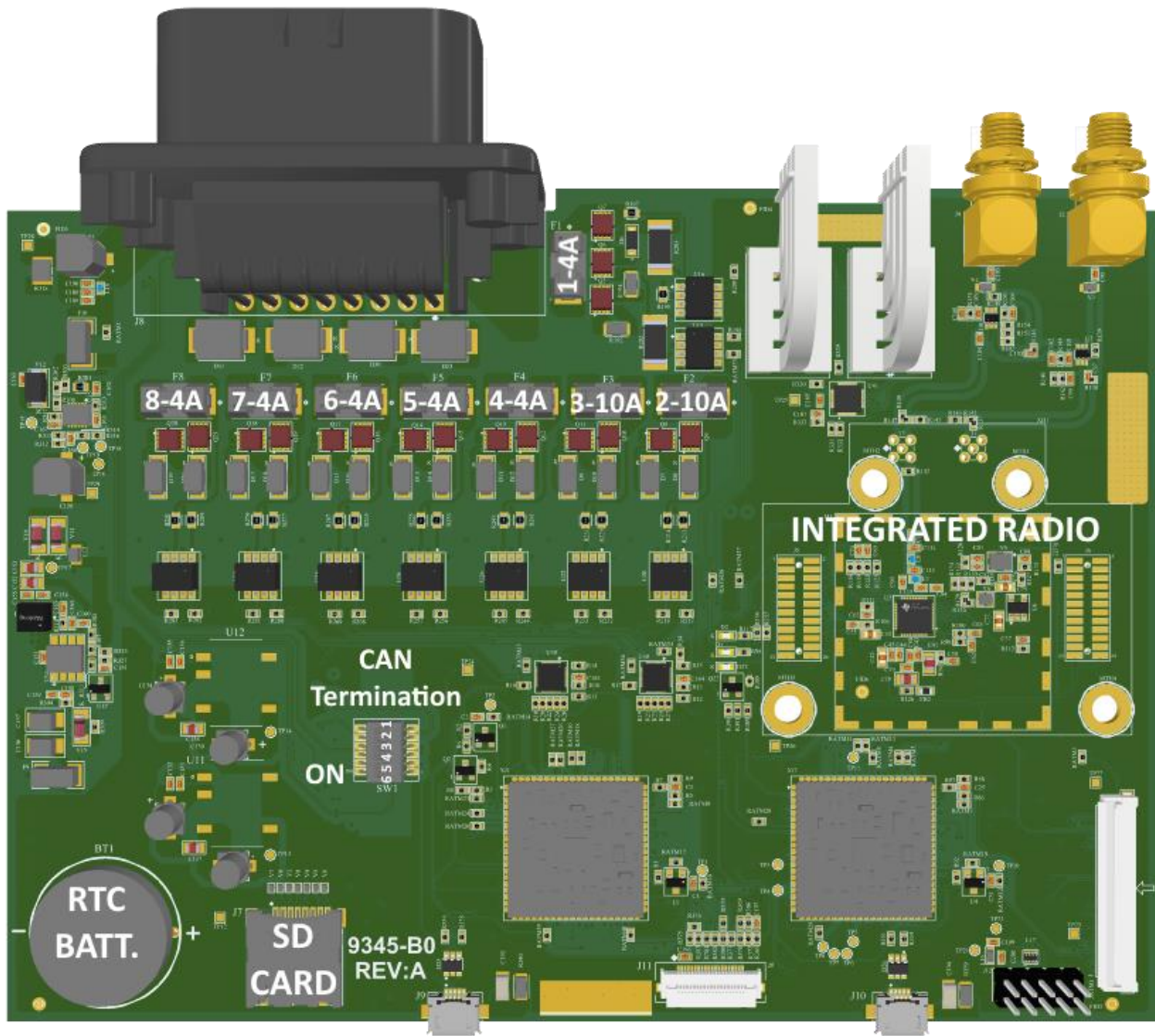

In the above image the primary serviceable and adjustable components are marked, Fuses are marked by channel and rating, (e.g. 5-4A is channel 5 rating 4A). See below for more information.



7.2 Radio Module

The integrated radio supports long range operation on 2.4GHz, requires no frequency management and enables high system density.

7.3 SD Card

The PumpBossIII MCU will accept a microSD or microSDHC card of up to 32GB capacity.

The card can be removed by pushing the top cover toward the center of the PCB until it unlatches, then lift cover.

The card slides into the lid / raised section with the connectors facing up at the hinge end.

To close the holder, fold the top down and slide toward the board edge.

7.4 Digital (SSR) Outputs

There are eight digital outputs each with multi-stage category 3 drive and monitoring, all rated for 9-36VDC, two at 10A and six at 4A, all support hit and hold PWM functionality and up to two may be defined as main power control outputs.

All outputs meet a PLd Functional Safety Level according to ISO13849

Figure 6 Fuses

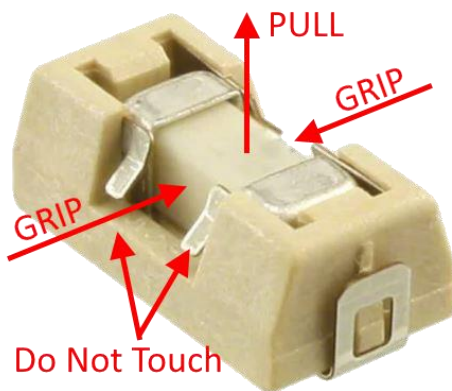

The Fuses for the eight Digital Outputs are inserted into a carrier as seen above, to remove the fuse, carefully grip the center of the fuse with needle nosed pliers and pull up, DO NOT GRIP THE SPRING RETAINERS or the carrier will be damaged. The new fuse can be pushed into the retainer, again being careful not to push on the spring retainers.

The fuses are 0453 series and either 4A (0453004.MR) or 10A (0453010.MR) as identified in the PCA Image above.



7.5 CAN interface

CAN Bus data handling is implemented in a category 3 PLd architecture so that both microcontrollers handle and cross verify the data ensuring that total fidelity is maintained.
The CAN interface features full voltage isolation.

CANbus Interface

The system supports an isolated CANbus interface with built in CANbus redundancy.

CAN INTERFACE CHARACTERISTICS	DESCRIPTION
CAN format	CAN 2.0A and CAN 2.0B
Bus speed	250, 500 and 1000 kbps
Standard	ISO 11898-2
Isolation	Each port is individually isolated for signals and power supply
Configuration	NodeID and baudrate are configurable through CattronLink Software

J1939 Operation

Maximum J1939 Transmit PGNs set to 8.
Maximum J1939 Receive PGNs set to 8.
Standard and Custom PGNs are supported.

CANOpen Operation

Maximum CANOpen Transmit PDOs set to 4.
Maximum CANOpen Receive PDOs set to 4.
Maximum CANOpen Safety PDOs set to 4.

The PumpBossIII operates as a CANopen NMT slave with fixed NodeID and fixed baud rate.
The CANopen operation state is independent from the RF connection status.
If the PumpBossIII is in Passive mode (before a RF connection, after an active STOP, or after a passive STOP) or in Error mode, all commands are reset to their safe values (zero)

CANOPEN SAFETY IMPLEMENTATION (SRDO)

SRDOs data length range from 1 to 8-byte. Multiple sub-indexes of different objects can be mapped and transferred on the same SRDO. The SRDO protocol follows the Producer/Consumer model.



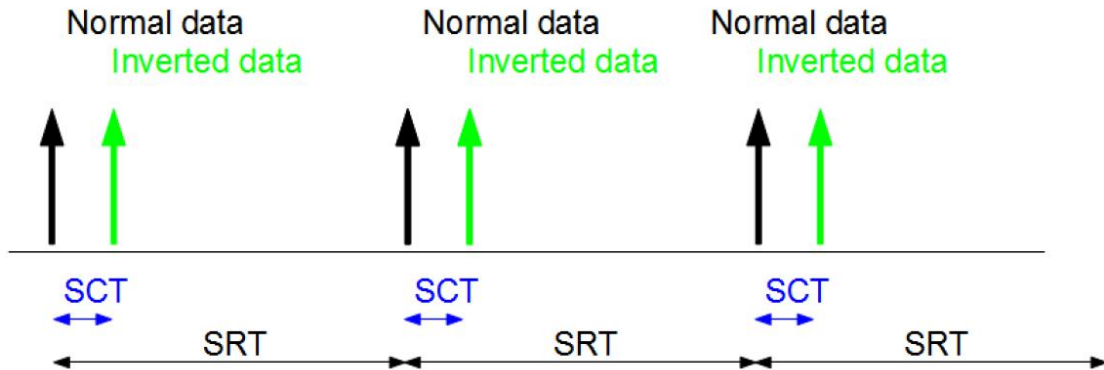

Figure 8 SRDO Transmission Protocol

SRDO

Two types of SRDOs are distinguished:

- SRDO producer shall be used to transmit Safety Related application data.
- SRDO consumer shall be used to receive Safety Related application data.

Secure transmission via the CAN bus

- Duplicate transmission with 2 independent CAN IDs.
- Transfer data normal and inverted.
- Cyclic transmission in fixed time frames.
- Fixed order of messages (normal followed by inverted).

Message monitoring while receiving

- Monitoring the correct sequence.
- Observance of time between normal and inverted messages.
- Observance of time between messages.



7.6 CAN Termination

Figure 7 CAN Terminations

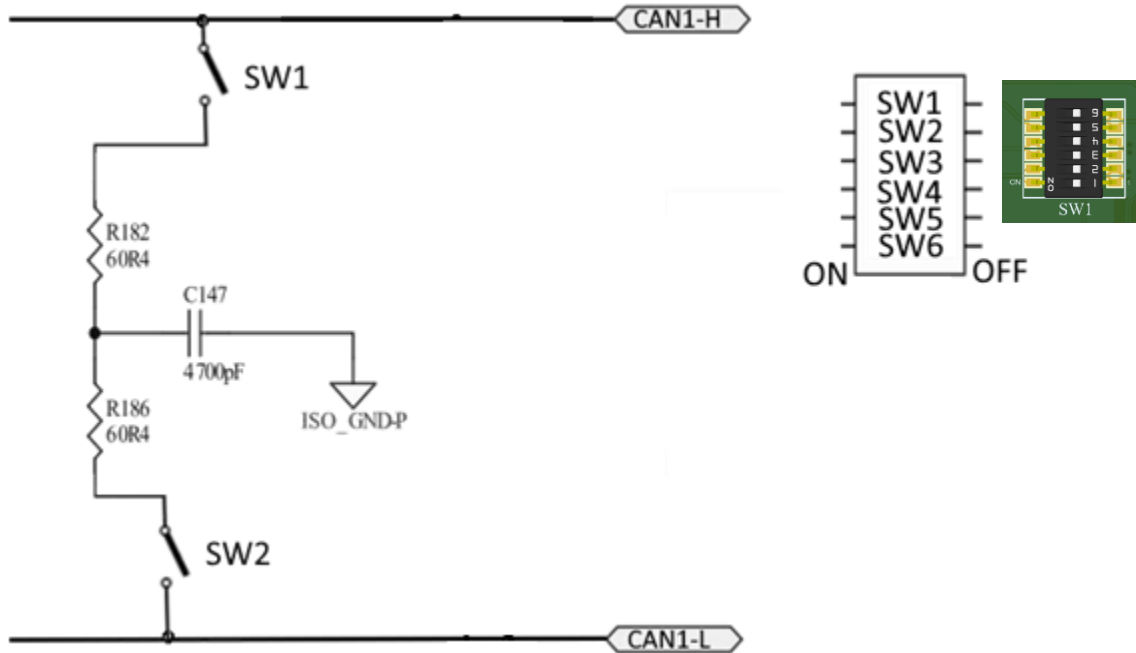

The CAN bus interface can be terminated as would be required if the PumpBossIII MCU is located at the end of a cable run. For CAN1, turn on switches 1 and 2. Switches 3,4,5 and 6 should be set to OFF.



7.7 Cable Harness

As illustrated in the following

Figure 8 Cable Harness

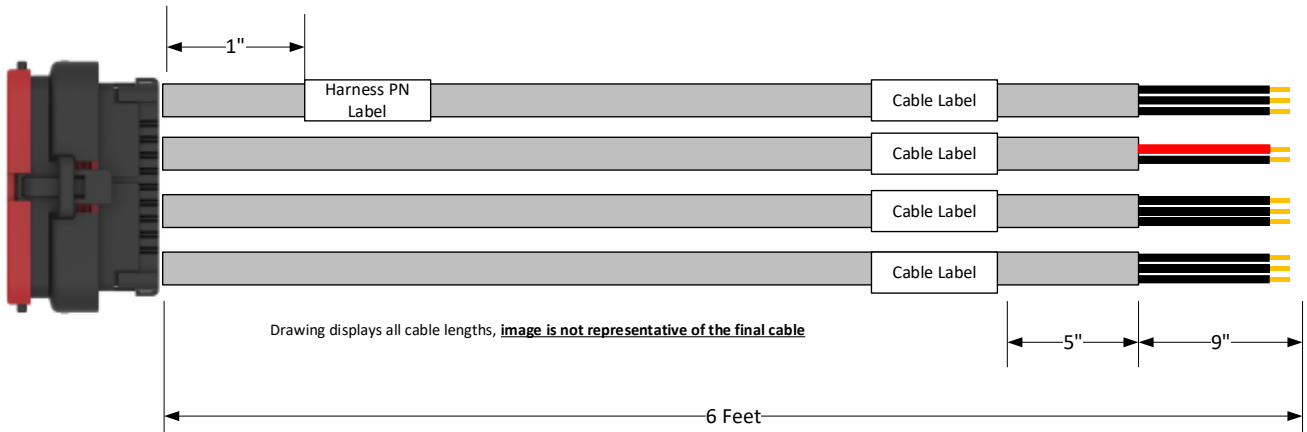

Figure 9 Main Connector

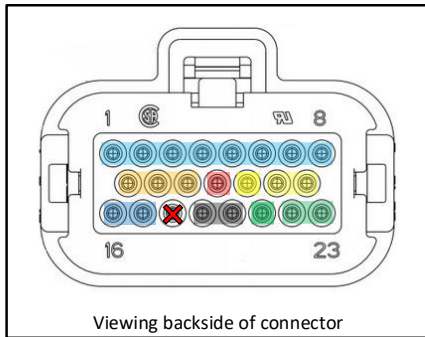

Table 1 Main Connector wire assignment

PIN #	Description	Rating	AWG	Color	CABLE	Wire Label
1	SSR Output #1	4A	18	BROWN	1	SSR 1
2	SSR Output #2	10A	18	WHITE	1	SSR 2
3	SSR Output #3	10A	18	ORANGE	1	SSR 3
4	SSR Output #4	4A	18	YELLOW	1	SSR 4
5	SSR Output #5	4A	18	GREEN	1	SSR 5
6	SSR Output #6	4A	18	BLUE	1	SSR 6
7	SSR Output #7	4A	18	VIOLET	1	SSR 7
8	SSR Output #8	4A	18	GRAY	1	SSR 8
9	SSR Channel Supply Inputs	8A	18	RED	1	SSR POS1
10		8A	18	RED\WHITE	1	SSR POS2
11		8A	18	RED\BLACK	1	SSR POS3
16	SSR Ground		18	BLACK	1	SSR GND
17			Shield	--	1	
13	CAN Bus #1 Shield-GND		Shield	--	3	
14	CAN Bus #1 - L		20	GREEN	3	CAN 1 - L
15	CAN Bus #1 - H		20	YELLOW	3	CAN 1 - H
18	Not used		PLUG		--	
12	CBMCU Input + (9-36V)		20	RED	2	POWER 9-36V
19			20	Black	2	POWER GND
20	CBMCU Input GND		Shield	--	2	
21	CAN Bus #2 Shield-GND		Shield	--	4	
22	CAN Bus #2 - L UNUSED		20	GREEN	4	CAN 2 - L
23	CAN Bus #2 - H UNUSED		20	YELLOW	4	CAN 2 - H

When making the SSR connections, note the maximum continuous current for any pin is 8A and the maximum total current is therefore 24A with all three SSR Channel Supply pins connected.

Peak output current on channels 2 and 3 is 10A but should not be maintained for more than 1 minute.

The SSR channels require a Ground reference to be connected, failure to do so will result in an error condition.



7.8 Status LEDs

As illustrated in the following figure, the PumpBossIII MCU has a total of 10 LEDs

Figure 10 Main Status LEDs

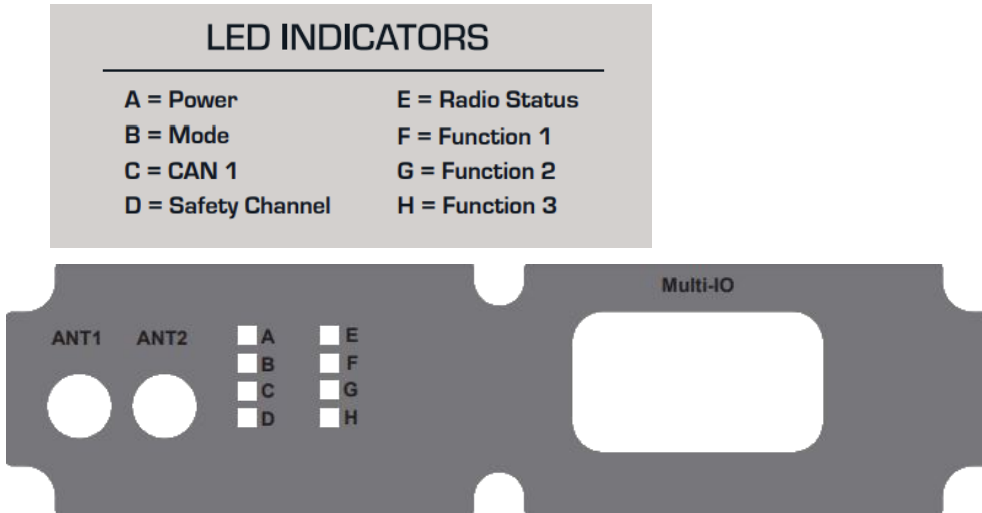

Status LED Functions

- LED A – Power Should be Orange indicating the presence of both 5V and 3V3, if the LED is RED, 3V3 is absent, if the LED is Green 5V is absent.
- LED B – Mode Flashing Red/Green, MCU starting and performing diagnostics
 Green, MCU in Run Mode, Normal operation
 Red, Error State, CAT1 or CAT2 error, error may clear
 Flashing Red, Error State, CAT3 error, unit requires service.
- LED C – CAN 1
- LED D – Safety O/P Red if ON, Green if OFF, LED OFF if no Safety Channel is assigned

The LEDs behavior in this section follow the terminology from CiA303-3 specification, listed below:

LED state	Description
On	The LED is constantly on.
Off	The LED is constantly off.
Flickering	The LED turns on and off with a frequency of 10 Hz: on for 50 msec and off for 50 msec
Blinking	The LED turns on and off with a frequency of 2.5 Hz: on for 200 msec and off for 200 msec



Single flash	Cyclic pattern: one short flash followed by a long off phase Cycle = on (200msec) – off (1000 msec)
Double flash	Cyclic pattern: two short flashes followed by a long off phase (1000 msec) Cycle = on (200msec) – off (200 msec) – on (200 msec) – off (1000 msec)
Triple flash	Cyclic pattern: three short flashes followed by a long off phase (1000 msec) Cycle = on (200msec) – off (200 msec) – on (200 msec) – off (200 ms) – on (200 msec) - off (1000 msec)
Quadruple flash	Cyclic pattern: four short flashes followed by a long off phase (1000 msec) Cycle = on (200msec) – off (200 msec) – on (200 msec) – off (200 ms) – on (200 msec) – off (200 msec) – on (200msec) - off (1000 msec)

J1939 Status LEDs

Red Component	CAN Error State
a. Off	Normal Operation. The unit is in Error Active state.
b. Blinking	CAN configuration error.
c. Single flash	Unit is in Error Passive State. At least one error counter (TEC or REC) has reached the warning limit of 128.
d. Quadruple Flash	PGN Receive Time-out: a PGN has not been received before its Receive Timer elapsed.
e. On	Bus-Off state

The Green component shall indicate the J1939 connection state, according to the following table:

Green Component	J1939 Connection State
a. Blinking	Address claiming in progress
b. Single flash	Address claiming failed
c. On	Address claimed success

CANopen Status LEDs

Red Component	CAN Error State
a. Off	No Error
b. Blinking	CAN configuration error
c. Single flash	Warning Limit Reached: at least one error counter (TEC or REC) has reached the warning limit. The unit is now in Error Passive state.



d. Double flash	Error Control Event: A guard event (Life guarding or Node guarding) or Heartbeat consumer event has occurred
e. Triple Flash	Sync error: The sync message has not been received within the configured cycle period time-out (ref: OD entry 0x1006)
f. Quadruple Flash	PDO Time-out: a PDO has not been received before its event timer elapsed
g. On	Bus-Off state

The Green component shall indicate the CANopen RUN Status, according to the following list:

Green Component	CANopen Run State
a. Blinking	PRE-OPERATIONAL
b. Single flash	STOPPED
c. On	OPERATIONAL

LED E – Radio Status

- Blue when CattronLink is connected
- Green Flash, Valid RF message received
- Amber Flash, Valid RF message received with RSSI below -90dBm
- Red Flash, RF message transmitted

LED F – Safety O/P Red if ON, Green if OFF, LED OFF if no Safety Channel is assigned

LED G – Function 1 Assigned by Application

LED H – Function 2 Assigned by Application

7.9 Error Behavior

The platform defines 3 error categories, where each category has its own error handling rules. This section defines the characteristics of each the categories.

Error Categories Overview

ERROR CATEGORY	NAME	DESCRIPTION
CAT1	Fatal System Error	Error affecting the Safety integrity of the device, as it may result in unpredictable and/or dangerous behaviour. CAT1 errors bring the Device in a permanent Safe State.
CAT2	Transient System Error	Errors related to possible transient conditions, that could be caused by EMI, or mechanical shock, for example. CAT2 errors forces a RESET Cycle, with complete boot-up diagnostic tests.



CAT3	Isolatable peripheral Error	<p>Errors related to a specific function or peripheral that can be isolated and disabled to a safe state without compromising the safety of the system.</p> <p>The faulty function or peripheral is kept disabled until the next power cycle.</p>
------	-----------------------------	---

Note: The LED behaviors associated with each type of error are already described in the Status LEDs section, LED B – Mode.

7.10 Data Logging

The PumpBossIII MCU features basic system diagnostic logging capabilities against a Real Time Clock. Data is stored on the SD card.

The data log can be accessed via CattronLink.

8 System Configuration

The PumpBossIII MCU is configured to suit a standard application, Cattron supplies a configuration sheet identifying OCU button to MCU output for each configuration to enable a smooth and successful implementation to be achieved.

Most applications will be standardized to suit a specific type of vehicle or machine, others may be developed as the need arises.

The types of collateral provided may include

- Installation Drawings
- Controller drawings
- Digital Output maps
- CAN configuration
- CAN mapping
- *.eds files
- Etc.

8.1 Operating Frequency

The PumpBossIII MCU is wirelessly paired with an Operator Control Unit (OCU) available in 2.4GHz and 915MHz frequency bands. The 2.4GHz frequency band uses frequency hopping, configuration is automatic as part of a simple push button sequence.

The 2.4GHz and 915 MHz frequency bands are license exempt.

8.2 System Address

Each Controller and MCU pair, shares a common, unique overall address. This address is contained in every telegram sent by the controller and is checked by the MCU every time an RF signal is received. The MCU processes a command only when the address in the telegram matches its own defined address. This is a critical safety measure to ensure that the MCU will act only upon its assigned controller.

CAUTION



	<p>Conflict of Addresses: Addresses are never repeated and are System Unique. The user must ensure that the system address and addressing mode is used as designed. The system address is marked on the OCU and MCU and must match. In the event of a breach of this undertaking, the user is liable for any resulting damage/loss and shall indemnify the manufacturer against all third-party liability claims.</p>
---	--

For 2.4GHz systems there is a dual layer of addressing, primarily the 48bit MAC address and also the 16 bit master address and the 8 bit sub address, however address allocation in a PumpBossIII system is fully automatic and part of the Association process.

For 2.4GHz systems the Controller and MCU must firstly know each other's 48 bit MAC Address, this is automatic using the Auto-Association method when 'MAC Association Mode' is set to Automatic as is the default setting, however it can be manually set if MAC Association Mode is set to Manual.

For 915 MHz systems the controller and MCU's address and frequency can be configured using Cattronlink.

Additionally, the Master Address must also match, the Master Address by default is also set automatically when 'Master Address Mode' is set to Auto MAC, but can be manually set, see examples below.



Figure 11 Default settings for Address Management

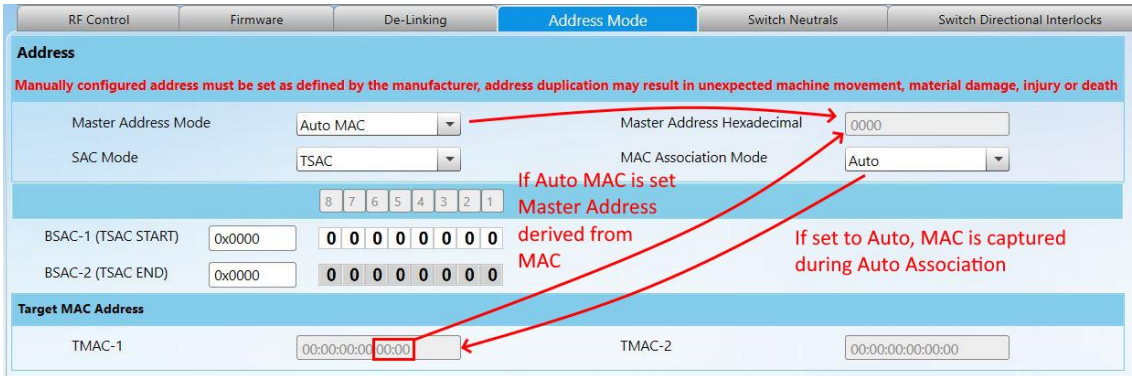

RF Control | Firmware | De-Linking | **Address Mode** | Switch Neutrals | Switch Directional Interlocks

Address
Manually configured address must be set as defined by the manufacturer, address duplication may result in unexpected machine movement, material damage, injury or death

Master Address Mode: Auto MAC
SAC Mode: TSAC
Master Address Hexadecimal: 0000
MAC Association Mode: Auto

8 7 6 5 4 3 2 1
BSAC-1 (TSAC START): 0x0000 | 0 0 0 0 0 0 0 0
BSAC-2 (TSAC END): 0x0000 | 0 0 0 0 0 0 0 0

Target MAC Address
TMAC-1: 00:00:00:00:00:00 | TMAC-2: 00:00:00:00:00:00

If Auto MAC is set Master Address derived from MAC
If set to Auto, MAC is captured during Auto Association

Figure 12 Manual Settings for Address Management

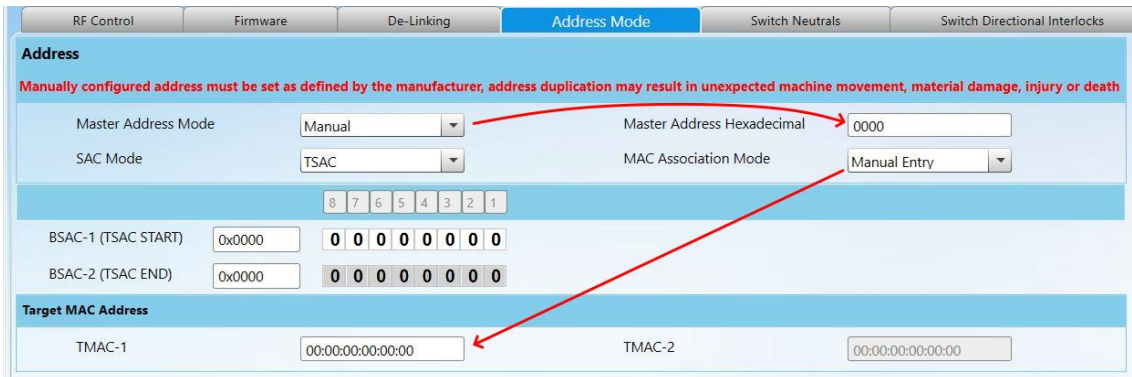

RF Control | Firmware | De-Linking | **Address Mode** | Switch Neutrals | Switch Directional Interlocks

Address
Manually configured address must be set as defined by the manufacturer, address duplication may result in unexpected machine movement, material damage, injury or death

Master Address Mode: Manual
SAC Mode: TSAC
Master Address Hexadecimal: 0000
MAC Association Mode: Manual Entry

8 7 6 5 4 3 2 1
BSAC-1 (TSAC START): 0x0000 | 0 0 0 0 0 0 0 0
BSAC-2 (TSAC END): 0x0000 | 0 0 0 0 0 0 0 0

Target MAC Address
TMAC-1: 00:00:00:00:00:00 | TMAC-2: 00:00:00:00:00:00



9 The Controlled Machine

9.1 Control Power

Your PumpBossIII MCU must be provided with a Power Supply and Control Supply of between 9 and 36V DC, these are connected via the multi-connector, an additional method of isolation may be desirable.

Note: The MCU motherboard is protected by three fast-blow fuses that are soldered to the printed circuit assembly, these are factory service items as a blown fuse would be indicative of other problems.

9.2 Main Safety Outputs

The PumpBossIII MCU may be programmed to assign up to two of its SSR outputs as Main Safety Outputs rather than Function control outputs.

Internally each output meets a Functional Safety level of category 3 PLd according to ISO13849, externally if a user needs a category 3 input they will require two outputs, otherwise a single output will provide them with a category 2 PLd input.

Main Safety Outputs behave differently than the other function outputs and are directly controlled by firmware rather than Application programming.

Main Safety Outputs can typically be thought of as an E-Stop function to bring the machine to a safe state.

Main Safety Outputs will be de-energized if,

- The MCU is without power

- The MCU has a fault

- If linked to another Control Unit (OCU or MCU) and a Stop command is received

- If linked to another Control Unit (OCU or MCU) and there is a communication failure (for any reason)

The need for and use of Main Safety Outputs depends on the risk assessment for the machine being controlled, that Risk Assessment is the responsibility of the integrator or user.

Generally, if a machine has the capability to cause injury or death if a failure occurred, then these Main Safety Outputs should be wired in such a way that they are controlling power (Electrical / Hydraulic etc.) to be able to place the machine in a safe state.

9.3 Circuit Breakers

One or more circuit breakers may be installed to isolate power to the machine to enable safe maintenance operations to be carried out.

9.4 Interfacing to the machine

Refer to the Configurations section for specific details of each standard configuration.

Non-Standard and customer specific configurations may be created for various applications and supplied with these systems as a separate document.



10 Operation

10.1 Post Installation

Before setting the system to work for the first time verify that the OCU and MCU are a system pair and share the same Master-Address and Sub-Address.

Do a visual inspection of the MCU to ensure it is clean, tidy and with no obvious defects, damage, loose wires etc. Verify machine operation in Manual mode.

Transfer operation to Remote mode and switch on MCU, check that the Status LEDs are as expected, as a minimum LED-A is Orange and LED-B is Green and if a Main Safety Channel has been defined LED-F will be Green.

Switch on the associated OCU and complete the OCU Start Sequence (Stop then Start or just Start depending on configuration), the OCU Stop switch will be flashing.

The PumpBossIII MCU LED-E will flash Green every time it receives a valid signal.
If Main Safety Channels are defined LED-F will have changed from Green to RED.

Check each function in turn for correct operation and direction.
Check any motion limit switches on the machine for correct operation.

Check the Stop function to ensure LED-F changes back to Green and the machine power resumes a safe state as expected.

Ensure the OCU is labelled completely and correctly and that the Crane or Machine is clearly identified on the OCU.

10.1 Associating an OCU with a Pump Boss III

For 915 MHz system, the OCU and MCU are already associated during manufacturing and production. A spare controller can be configured using Cattronlink.

For 2.4 GHz system, if an OCU has not previously been associated with a Pump Boss III, then it is necessary to follow a simple procedure to associate them, this is a process where the OCU and MCU exchange their addresses so that they may be able to securely operate.

This process is called Association and can be carried out either directly or using CattronLink™

- A. An OCU can only be used with the last MCU to which it was associated.
- B. An MCU can only store the identities of eight OCUs, e.g. operating unit 1, spare 1, spare 2 etc. after eight OCUs have been associated the MCU would need to have its list deleted by using CattronLink.
- C. To initiate the association process the MCU should be in Passive mode (turned on but not operating with any OCUs.)
- D. The OCU to be associated should be woken from sleep and in passive mode so the green status LED is illuminated.
- E. Make sure the OCU is as close to the MCU antenna as possible and certainly closer to the intended MCU than any other MCU. (***The OCU will associate with the MCU with the strongest RF signal***).
- F. Press and hold the two buttons shown below on the OCU for more than 10 seconds, the Status LED will turn Blue, release the buttons.
- G. At successful completion of Association, the OCU status LED will revert to Green, if the association fails it will change to Red and association should be re-tried.



- H. Now press and hold the Stop button to turn off the OCU, turn it back on again and complete the Start sequence so the Stop switch is flashing, then using the On/Alarm button verify that the correct MCU is being controlled.

Figure 13 OCU Association Buttons



Table 2 Association LED Sequence

Sequence	LEDs				Time LED
	E-Stop	STATUS	1	2	
Association Process Start/In Progress	OFF	BLUE	OFF	OFF	Status LED BLUE(CONST) After pressing START Button for 10 Sec
Association Process Fails	OFF	GREEN	Red	OFF	Status LED passive, LED1 red (5 Sec)
Association Process Success	OFF	GREEN	GREEN	OFF	Status LED passive, LED1 Green (1 second)

10.2 Turning on your OCU

From an OFF state the OCU can be powered up by pressing the START button, this will wake the OCU to a fully tested PASSIVE mode where it is waiting for user input to move into another operational mode. The LEDs and Haptic will be tested at this point so you will see all LEDs flash briefly to confirm they are all working.



The center Status and Right-hand LEDs 1 & 2 will then illuminate, the battery status will be shown on LEDs 1 & 2, after a few seconds LED1 & 2 will turn back OFF.

Table 3 Switch ON LED Sequence

Sequence	LEDs				Function
	E-Stop	STATUS	1	2	
Entering Passive State		GREEN			
At switch on after self test	RED	RED	RED	RED	quick verify of LEDs & haptic
		GREEN	GREEN	GREEN	
		BLUE			
INTERNAL Error		RED			
CAT 2 Error		N/A			
SWITCH Error		ALT. RED/GRN			Alternating Red/Green with Battery state masked
Pause					
Passive State	OFF	GREEN	GREEN	GREEN	Battery more than 80%
	OFF	GREEN	GREEN	AMBER	Battery 60-80%
	OFF	GREEN	AMBER	AMBER	Battery 40-60%
	OFF	GREEN	AMBER	RED	Battery 20-40%
	OFF	GREEN	RED	RED	Battery less than 20%

10.3 Transition to Active Mode

From Passive Mode the OCU can be moved into Active (Transmitting) mode by pressing the Start button again.

At this stage all switch elements are tested to ensure that none of them are activated before the OCU transitions into the active machine controlling mode.

Table 4 Active Mode LED Sequence

Sequence	LEDs				Function
	E-Stop	STATUS	1	2	
Active State Transmission Battery >40%	RED F	OFF			Active and E-Stop available
Active State Transmission Battery 20-40%	RED F	AMBER F			Active and E-Stop available
Active State Transmission Battery <20%	RED F	RED F			Active and E-Stop available

At this point the OCU is operative and the target machine will be under direct control, verify the connection by activating a non-motion function.



Test all functions briefly at the start of the work session.

	<p>WARNING</p> <p>Before attempting to use the system, verify the target crane or machine you wish to operate is under the direct command of your OCU. This is accomplished by operating a non-motion OCU function such as the horn and observing that the horn sounds on the targeted crane or machine. Failure to implement the above may result in serious injury or death to personnel and damage to equipment.</p>
---	--

10.4 Transition to Passive Mode

The machine may be brought to a halt at any time by simply releasing the motion control button that will deactivate the motion control, or in an emergency pressing the STOP button that will typically deactivate the machine. When the STOP button is pressed the OCU sets the STATUS LED Red and the ESTOP LED Green and sends a positive stop command to the MCU and then terminates transmission, both of which will deactivate all commands and de-energize the machine.

From this stage the OCU can either be transitioned back to Active mode or switched off.

10.5 Transition to OFF Mode

From Passive mode the OCU can either be left until it powers down automatically after 3 minutes, or manually put to sleep by pressing and holding the STOP button for 3 seconds.

10.6 Turn ON Procedure

From OFF, press START and wait until the Status LED is green, then press START again, the Stop switch will now be flashing red.

10.7 Daily Operation

Before setting the system to work each day ensure the correct OCU is being used by checking that the Machine ID on the back of the OCU matches the machine to be controlled and that the OCU is in free from any obvious damage.

Switch on the associated OCU (Press Start) and complete any required Start Sequence, observe the OCU status is normal.

Check to ensure the correct machine is under control, then if safe to do so briefly check each function in turn for correct operation and direction.

Check the Stop function to ensure the Machine resumes a safe state.

10.8 Service

In the event of any problems, it is always wise to examine the installation for common problems such as loose connections and damaged wiring including antennas and coaxial cables, these same checks should be made annually.



The Pump Boss III features diagnostic Data-Logging that records all system data. In the event that system operational problems exist, the log can be downloaded remotely from a PC with a Bluetooth connection, this log can be analyzed by Cattron or an experienced person to examine it for clues relating to possible problems, these may be related to the remote-control system or other items such as RF interference, loss of power etc.

If no obvious faults can be located, contact the Cattron Service Team for further assistance at www.cattron.com/contact

10.2 De-commissioning

If the system is to be de-commissioned ensure that the machine is left in a safe operational state, in the case of a plug in MCU this may be as simple as isolating machine power and unplugging the MCU, but if the MCU is directly wired into an interface panel, this should be completed by a qualified electrician familiar with the machine in question.

11 Configurations

11.1 PBIIS-1

Covers most standard pumping applications.



PIN #	Description	Rating	AWG	Color	CABLE	Wire Label	Function	OCU Switch
1	SSR Output #1	4A	18	BROWN	1	SSR 1	SAFETY	STOP/OFF
2	SSR Output #2	10A	18	WHITE	1	SSR 2	PUMP (L)	2 ON, 3 OFF
3	SSR Output #3	10A	18	ORANGE	1	SSR 3	REVERSE (L)	11 ON, 10 OFF
4	SSR Output #4	4A	18	YELLOW	1	SSR 4	RPM INC	4
5	SSR Output #5	4A	18	GREEN	1	SSR 5	RPM DEC	5
6	SSR Output #6	4A	18	BLUE	1	SSR 6	VOL INC	12
7	SSR Output #7	4A	18	VIOLET	1	SSR 7	VOL DEC	13
8	SSR Output #8	4A	18	GRAY	1	SSR 8	HORN	9
9	SSR Channel Supply Inputs	8A	18	RED	1	SSR POS1		
10		8A	18	RED\WHITE	1	SSR POS2		
11		8A	18	RED\BLACK	1	SSR POS3		
16	SSR Ground	18		BLACK	1	SSR GND		
17			Shield	--	1			
13	CAN Bus #1 Shield-GND		Shield	--	3			
14	CAN Bus #1 - L		20	GREEN	3	CAN 1 - L		
15	CAN Bus #1 - H		20	YELLOW	3	CAN 1 - H		
18	Not used		PLUG		--			
12	CBMCU Input + (9-36V)		20	RED	2	POWER 9-36V		
19	CBMCU Input GND		20	Black	2	POWER GND		
20			Shield	--	2			
21	Not Used		Shield	--	4			
22	Not used		20	GREEN	4	CAN 2 - L		
23	Not used		20	YELLOW	4	CAN 2 - H		



11.2 PBIIS-2



PIN #	Description	Rating	AWG	Color	CABLE	Wire Label	Function	OCU Switch
CONFIG 2								
1	SSR Output #1	4A	18	BROWN	1	SSR 1	SAFETY	STOP/OFF
2	SSR Output #2	10A	18	WHITE	1	SSR 2	LEFT FORWARD	2
3	SSR Output #3	10A	18	ORANGE	1	SSR 3	LEFT REVERSE	3
4	SSR Output #4	4A	18	YELLOW	1	SSR 4	RIGHT FORWARD	10
5	SSR Output #5	4A	18	GREEN	1	SSR 5	RIGHT REVERSE	11
6	SSR Output #6	4A	18	BLUE	1	SSR 6	BOTH FORWARD	4
7	SSR Output #7	4A	18	VIOLET	1	SSR 7	BOTH REVERSE	5
8	SSR Output #8	4A	18	GRAY	1	SSR 8	HORN	9
9		8A	18	RED	1	SSR POS1		
10	SSR Channel Supply Inputs	8A	18	RED\WHITE	1	SSR POS2		
11		8A	18	RED\BLACK	1	SSR POS3		
16	SSR Ground		18	BLACK	1	SSR GND		
17			Shield	--	1			
13	CAN Bus #1 Shield-GND		Shield	--	3			
14	CAN Bus #1 - L		20	GREEN	3	CAN 1 - L		
15	CAN Bus #1 - H		20	YELLOW	3	CAN 1 - H		
18	Not used		PLUG		--			
12	CBMCU Input + (9-36V)		20	RED	2	POWER 9-36V		
19	CBMCU Input GND		20	Black	2	POWER GND		
20			Shield	--	2			
21	Not Used		Shield	--	4			
22	Not used		20	GREEN	4	CAN 2 - L		
23	Not used		20	YELLOW	4	CAN 2 - H		



11 CattronLink™

	WARNING
	<p>More than one remote control system may be used at, around, or nearby your operating facility. Therefore, before selecting an address for a system or spare you must ensure that it is the correct address for the desired equipment to be operated.</p> <p>If the wrong address is programmed into an OCU or MCU, other remote-controlled equipment located at, around, or nearby your facility may unintentionally become operational.</p> <p>Failure to comply with the above warnings may result in serious injury or death to personnel and damage to equipment.</p>

These systems feature the latest innovations in Safety, Programming and Configuration that enable continuous performance and feature upgrades to be a simple process.

There are two parts to this;

1. The Firmware that includes the core safety functions and the Features that have been integrated to give the unit its capabilities.
2. The Configuration Parameters that apply to each feature, these configuration parameters include such items as Operating Frequencies, Address, Addressing Mode, Time-share Algorithms as well as the Digital and CAN mapping etc.

The Firmware may contain features that are not configured or used. Configuration parameters that are not available in the firmware will not be implemented even if loaded in the Configuration file.

Therefore, as features are release the firmware needs to be upgraded in order to benefit from them (if wanted).

Due to this flexible and easily upgradeable configuration concept, it is not uncommon for one MCU to be kept as a spare for multiple cranes or machines, even if with widely varying functionality.

All OCU and MCU access is carried out wirelessly over a Bluetooth link from a laptop or PC running the Cattron software utility called CattronLink™.

11.1 What is CattronLink™ Software.

CattronLink™ software is a suite of Apps that enable the latest generation of Cattron remote control products to be accessed over a Bluetooth® link for the purposes of;

- Firmware Upgrades
- Loading or changing of configuration parameters
- Examining device status including switch and relay totalizers
- Examining the datalogging stores.

NB: Not all features of CattronLink™ are available for all systems

The User manual for CattronLink™ can be found on the Cattron.com website



12 Requirements to Achieve PLd within a ‘System’

The PumpBossIII MCUs meet a PLd rating for all digital outputs, additionally one or two of these may be defined as Main Safety Outputs to control machine power providing a category 2 (single channel) or a category 3 (dual channel) input to the controlled machine.

The CANbus output also meets a PLd rating as it is controlled and monitored in a category 3 architecture ensuring that there can be no corruption of data within the system. Protection of the data being handled can either be accomplished by implementing deterministic and security elements within the payload.

The PumpBossIII System, (The OCU and MCU combined) has a PLd rating for its STOP function.

13 PFHd Values

Function	Exclusions	MTTFd	MTTFd Rating	Dcavg	Dcavg Rating	Cat	PLr	CCF	Meets Minimum Requirement of PL d	PFHd	PL
DC DIG 1	NO	183	HIGH	98.6	MEDIUM	3	d	YES	YES	4.29E-08	e
DC DIG 2-8	NO	226	HIGH	98.5	MEDIUM	3	d	YES	YES	4.29E-08	e
DC CAN	NO	257	HIGH	98.1	MEDIUM	3	d	YES	YES	4.29E-08	e

NB: MTTFd values capped at 100



14 Technical Specifications

Refer to datasheet on resources tab of product on website

<https://www.cattron.com/resources/>

15 CE Declaration of Conformity

Hereby Cattron declares that the radio equipment is in compliance with Directive 2014/53/EU. View the EU Declaration of Conformity document. www.cattron.com



Due to continuous product improvement, the information provided in this document is subject to change without notice.

Cattron Support

For remote and communication control systems support, parts and repair, or technical support, visit us online at:
www.cattron.com/contact

Cattron North America Inc., 655 N River Rd NW, Suite A, Warren, OH 44483